

55



CRUISER 55

Sailing on a grand scale

The CRUISER 55 is the flagship of the CRUISER line and embodies modern living at sea. The sleek, exterior lines, wide, spacious decks and extravagant living space below-deck are impressive. An easily accessible, large dinghy garage is built in to this capacious yacht and has been designed to stow an inflatable tender with outboard engine quickly and safely in any weather conditions. Remarkably for her size, the CRUISER 55 is amazingly easy to handle.



55 | Premier space and comfort



Clear lines and space are design characteristics of the exterior and interior of the CRUISER 55. The generous layout of the rooms offer maximum comfort on the dock, at anchor or out at sea. The fully equipped pantry and freestanding galley island make cooking a special pleasure.





3-cabin version



4-cabin version A

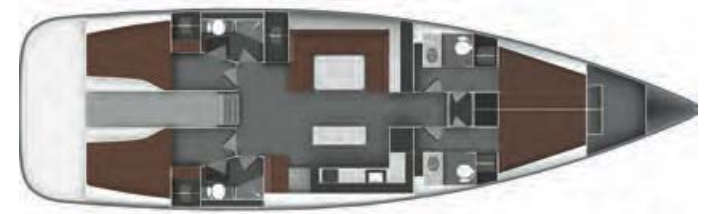

4-cabin version B



5-cabin version



Owner's version after modification of the charter version

55 | Technical data



Mainsail	77 m ²
Foresail	68 m ²
Gennaker	198 m ²
I	19.90 m
J	6.51 m
P	19.25 m
E	6.76 m

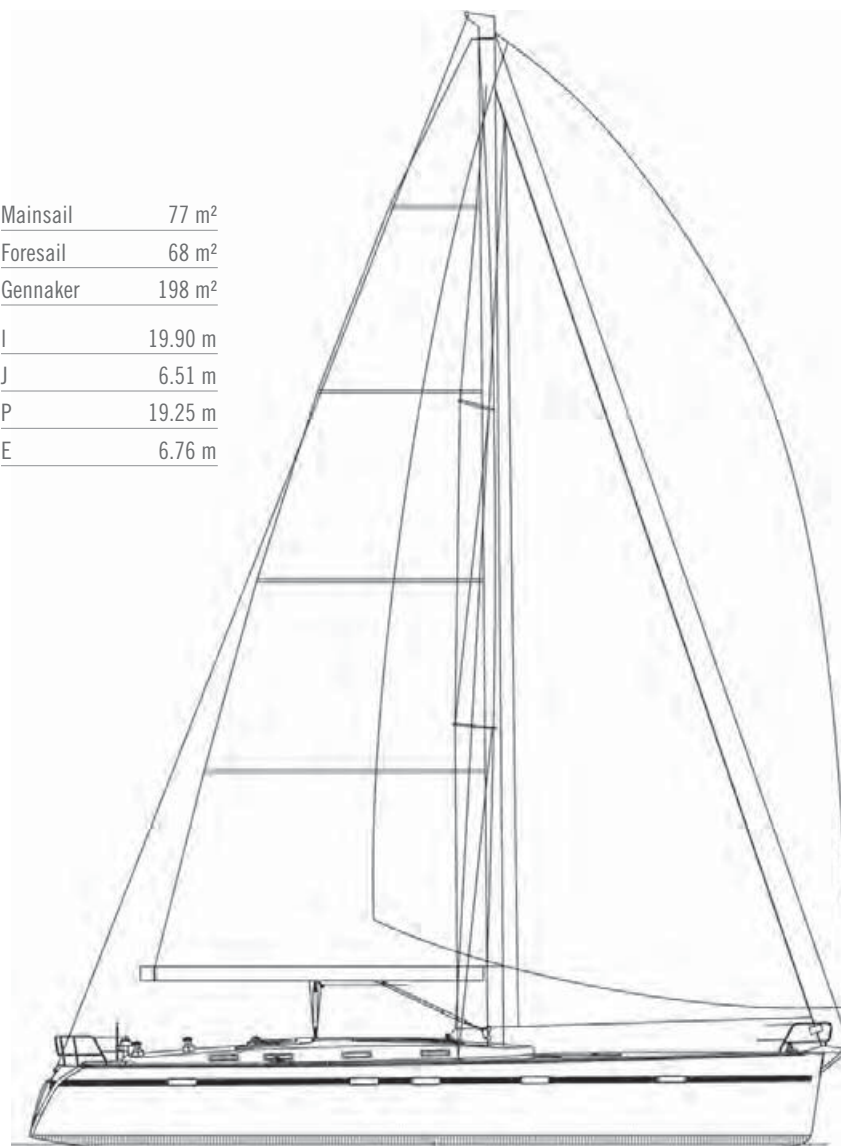

Sail plan



Deck layout

Length overall	16.75 m
Length hull	16.16 m
Length waterline	14.96 m
Beam overall	4.87 m
Draught standard (option)	2.35 m (1.90 m)
Light weight displacement	17,200 kg
Engine	Yanmar 4JH4-HTE
Engine power	81 kW (110 PS)
Fuel tank	300 l

Water tank	700 l
Cabins	3/4/5
Berths	6/8/10
Height in salon	2.06 m
Mainsail and roller furling genoa, standard	145 m ²
Height of mast above waterline	23.25 m
Passengers	16
CE category	A

All data is subject to change without notice and given without warranty.

