

40



# CRUISER 40



## Magnificent prospects

The CRUISER 40 exudes an air of comfort and warmth. Numerous flush-mounted windows and hatches in the hull and deck provide plenty of ambient light. At night the ceiling lights create a cosy atmosphere. An impressive amount of space creates uniquely comfortable living conditions.

# 40 | Relaxation for the whole family



Carefully designed details and generous space characterise the CRUISER 40. Moreover, its ergonomic shapes, an abundant use of wood and strategically placed easy-care surfaces combine to deliver a striking interior.





2-cabin version

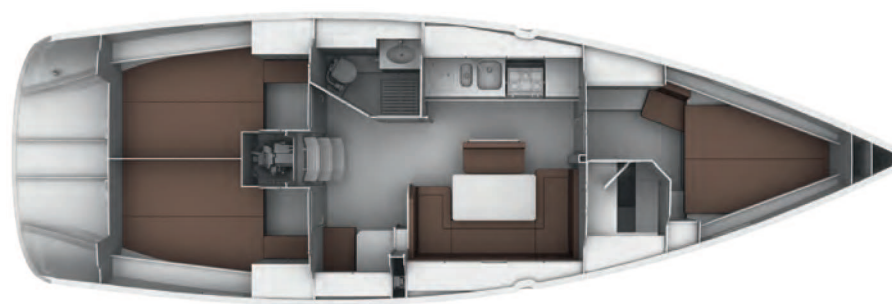

3-cabin version

# 40 | Technical data



Mainsail	48 m <sup>2</sup>
Foresail	34 m <sup>2</sup>
Gennaker	102 m <sup>2</sup>
I	15.83 m
J	4.20 m
P	15.36 m
E	5.27 m

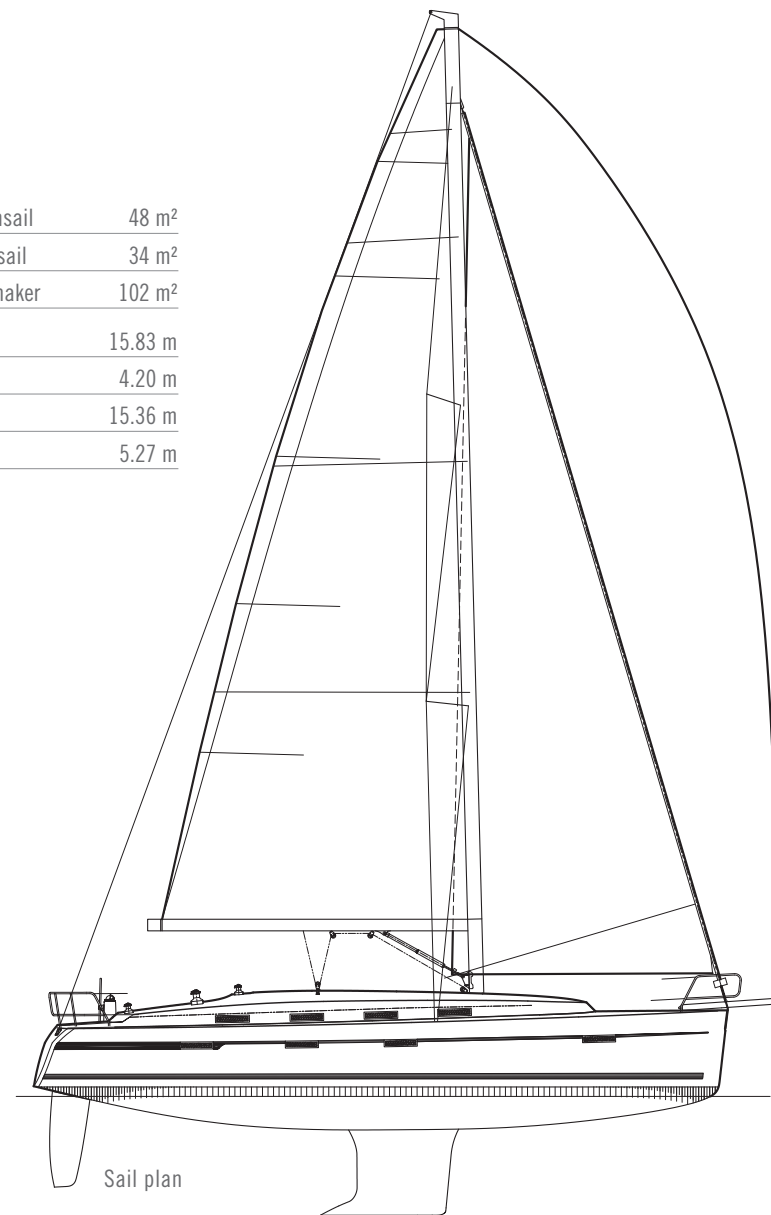

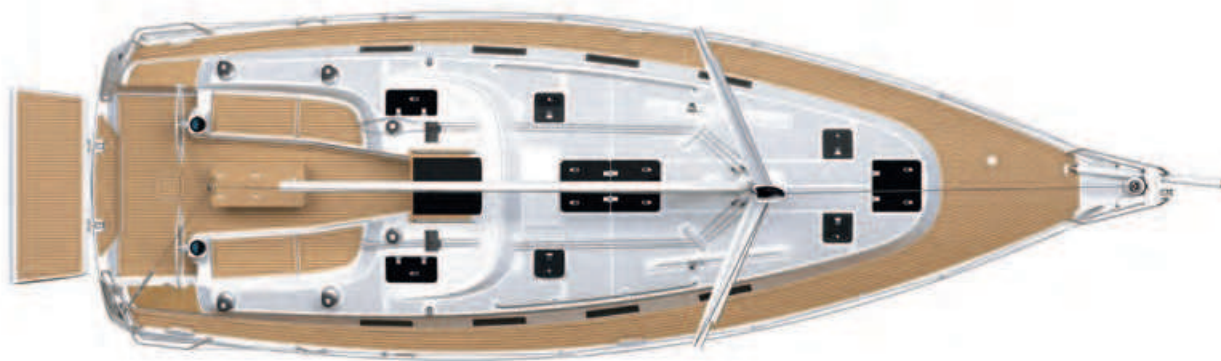

Deck layout

Length overall	12.35 m
Length hull	11.99 m
Length waterline	10.75 m
Beam overall	3.96 m
Draught standard (option)	2.05 m (1.65 m)
Light weight displacement	8,680 kg
Engine	Volvo Penta D1-30
Engine power	21 kW (29 PS)
Fuel tank	210 l

Water tank	210 l
Cabins	2/3
Berths	4/6
Height in salon	1.97 m
Mainsail and roller furling genoa, standard	82 m <sup>2</sup>
Height of mast above waterline	18.68 m
Passengers	8/14
CE category	A/B

All data is subject to change without notice and given without warranty.

